

Franke Coffee Systems

Flair:

The charming way of enjoying coffee.



FRANKE

COFFEE
SYSTEMS

The art of excellent coffeemaking

Flair:

The fine art of coffee in irresistible quality.

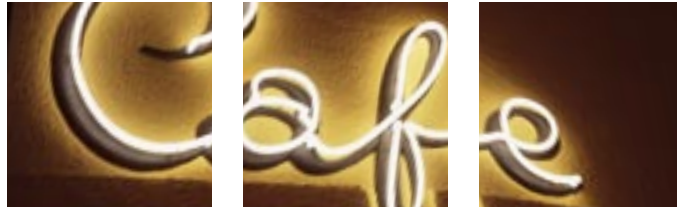

Being seduced by the charms of the Flair is never a disappointing experience; after all, it fulfils virtually every wish. The Flair offers you ultimate user convenience and your guests an irresistible coffee experience. So if you're not prepared to do without the advantages of a large coffee-making machine yet don't require a large coffee output, the Flair is the ideal coffee machine for you. Indeed, in small catering businesses and offices, they're celebrating nothing less than:

The art of excellent coffeemaking



Flair:

A certain added refinement.



Operating panel

Simple and efficient. With its ergonomic operating panel with eight product buttons for coffee and milk specialities and a clearly arranged LCD the machine is ideally suited for every application – in both self-service operation and waiter operation. The product labelling can be fully customised. There are also two separate dispensers for hot water and steam. So easy operation and extremely simple handling are the key characteristics of the Flair.



Customised settings

If required, the customer has the possibility of setting his own key parameters for the amount of coffee to be ground and the amount of water required or even the coffee temperature, quickly and individually. The coffee output itself is monitored by various counter functions. To change the products you wish to offer, simply reprogramme the new product and alter the product name on the display – no need to call out customer service. Each individual setting is always confirmed by the corresponding reading on the display.



Dispenser area/operating area

Adaptable and sturdy. The steplessly height-adjustable coffee/milk dispenser (75–150 mm) means you can use all the popular sizes of cups and containers. With this combined dispenser, coffee and milk products are obtained at the touch of a button, without having to shift cups and glasses out of the way first. The dispenser is extremely easy to dismantle and can be cleaned in a dishwasher without any problem.

Cleaning/hygiene/descaling

The integrated automatic rinsing, cleaning and descaling programme for the coffee and milk unit greatly facilitates the maintenance and care of the coffee machine, and ensures optimum hygiene and a consistently high coffee quality.

Milk system:

Comes with an enticing diversity of recipes.

System-based milk preparation

On the Flair the milk/foamed milk devices are integrated into the dispenser system as standard, which means you can dispense coffee and foamed milk or coffee and warm milk simultaneously. The milk/foamed milk output sequence is programmable – either before, during or after the coffee. The cool box stores the milk at a constant 5°C, keeping up to 2 litres of milk fresh for an extended period. The chromium steel milk container is easy to refill and

can be removed when the machine is not in use and stored in the cool box.

The automatic rinsing and cleaning programme makes sure the milk is processed under totally hygienic conditions at all times. The two milk/foamed milk devices are rinsed automatically after a pre-programmable period of time. They are easily accessible and, if required, can be removed for cleaning without the need to call out customer service.

Milk preparation at a glance

- Hot milk or foamed milk dispenser
- Consistent dosing
- Automatic cleaning and rinsing programme
- Self-service-compatible (including billing)

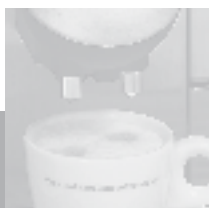

The useful extras: A la carte options, billing systems and add-on units.

Flair options

- Silver finish
- Permanent connection to water mains (available for both water containers, 5 l and 3 l)
- Drainage for drip tray
- Coffee-bean container extension to 2 × 500 g
- Coffee grounds chute

Billing systems

As an option the Flair can be equipped to operate with commercially available billing and dispensing systems such as coin validators and/or card scanners. The chosen system is then mounted inside a compact casing integrated into the machine. A 3-litre water container is used for this type of operation.

- U-Key/Legic /EC Cash
- Token/coin validator
- Chip-card system

Add-on units

Cool box (2 l): Stores fresh milk at a constant 5 °C, in conditions of perfect hygiene. Easy-to-clean refrigerated compartment and milk container.



Applications:

Wherever quality and enjoyment are top of the bill.

Customers who receive attentive service become loyal customers. Staff who are satisfied are simply more productive. And approving guests become regular guests. So whether at service stations, bakeries, take-aways, service-rendering companies or in the small-scale catering and restaurant trade, the Flair is always a boost to business –

offering coffee enjoyment of the very highest quality.



Flair:
Strikingly intelligent, astonishingly
adaptable.

The Flair is clearly the result of perfected coffee-machine expertise. One glance at the smart practical features says it all. Two grinders for different roasts and plenty of scope for genuine variations in taste, eight coffee and milk specialities at the touch of a button, steam and hot water dispensed simultaneously, and an attractive design. It's all simply convincing.



Flair: Facts & Figures.

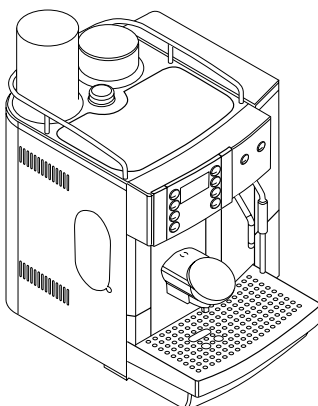
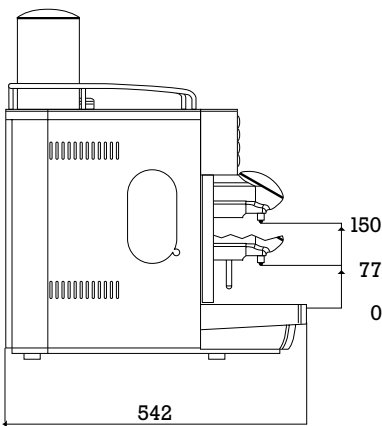
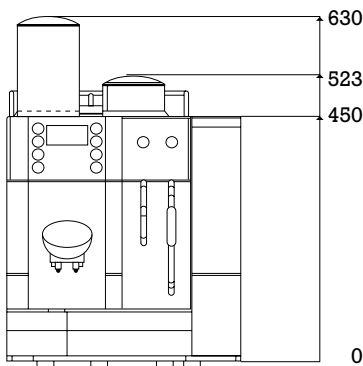

Standards

- High-performance piston coffee machine with pre-infusion
- 2 high-precision grinders with direct grinding
- Individual grinder selection, with ground coffee blended for each product
- Coffee-bean level monitoring
- Controlled quantity of hot water output
- Steam dispenser for separate milk heating
- Operating panel with 10 product buttons including hot water and steam button
- Fully electronic control board with illuminated LCD
- Individual programming of the water, ground coffee and milk quantity for each product
- 3 separate brewing temperatures
- Automatic rinsing, cleaning and descaling programme for coffee and milk unit
- Adjustable combined dispenser 75 to 150 mm with 2 integrated cappuccinators for milk froth and hot milk
- Dry coffee grounds ejected into tray, with overflow safeguard
- Direct dispensing of coffee and milk foam at the touch of a button
- Provision for connection to dispensing and billing systems
- Casing colour: standard black with CNS front cover, option silver with CNS front cover

| | |
|------------------------------|--|
| Dimensions | W = 423 mm, D = 542 mm, H = 523 mm above bean container |
| Weight | 20 kg |
| Electrical connection | 1 × 230 V AC, 2.3 kW, 10 A |
| Water supply | Side water tank, 5.5 litres capacity; permanent connection to water mains (optional) |
| Residual water | Drip tray with monitoring, 1.5 litres capacity; fixed drain (optional) |
| Bean container | 2 containers, 250 g each |
| Grounds container | 40 cakes |
| Daily output | The unit is designed to handle an average daily output of approx. 100 cups |
| Spot output | 2 cups of espresso/coffee/cappuccino/latte macchiato/hot milk/hot water per minute |